

Largest Configuration - Typical
Video Production with Audio Mix, LD Bench, Producer Bench
 Minimum Active Space Needed: 270 sq ft., Typical Dead Case Storage Space Needed: 100 sq ft

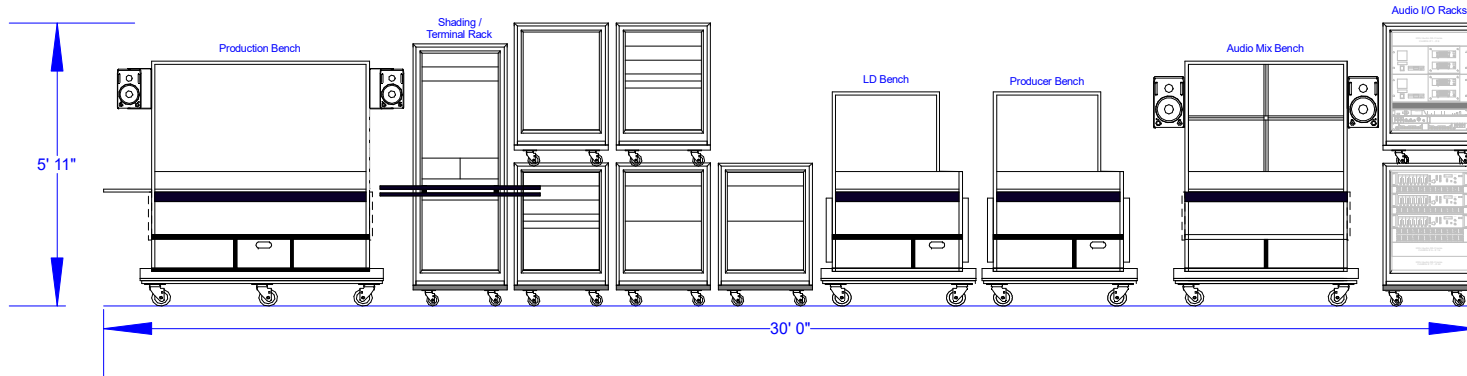

Aprx. Power Draw:
 105 amps
 Example (7) 15a
 110v circuits

Smallest Configuration - Typical
Video Production
 Minimum Working Space Needed: 135 sq ft., Dead Case Storage Space Needed: 50 sq ft

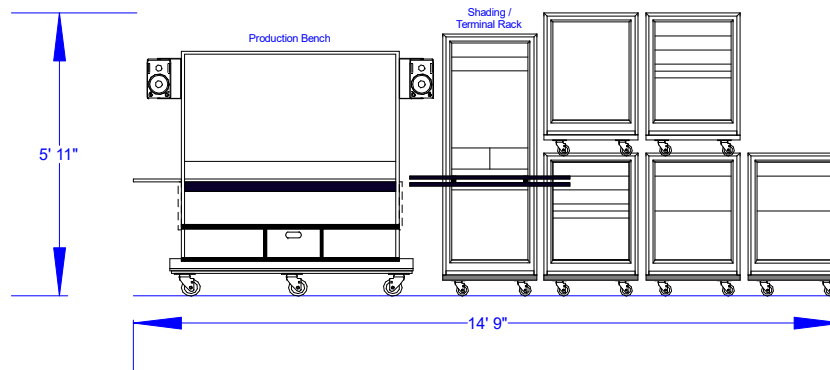

Aprx. Power Draw:
 90 amps
 Example (6) 15a
 110v circuits

Audio Mix / ProTools - Typical
 Minimum Working Space Needed: 60 sq ft., Dead Case Storage Space Needed: 10 sq ft.

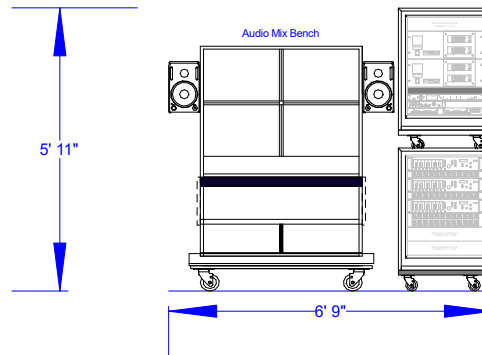

Aprx. Power Draw:
 15 amps
 Example (1) 15a
 110v circuits